



by **Schneider** Electric

I N S T A L L A T I O N

ExSite® EHXM Series Explosionproof Fixed System



C1306M-D (7/09)

Contents

Important Safety Instructions	3
Getting Started	4
Methods of Installation	4
Install the Power Module	5
Connect Wiring	6
DIP Switch Settings	7
Protocol Settings	7
Receiver Address Settings (SW1)	7
Termination Setting (SW2)	7
Baud Settings (SW3)	7
Install the Camera Module	12
Install the Enclosure and Set Pan Position	15
Set the Tilt Angle of the Camera Module	16
Install the Sun Shroud	17
Maintenance	18
Camera Module Replacement	18
Specifications	21
Camera/Optics	22

List of Illustrations

1 Methods of Installation	4
2 Attach Power Module to Mounting Surface	5
3 Default DIP Switch Settings	7
4 Loosen Set Screw	12
5 Remove Back Cap of Camera Enclosure	12
6 Install Camera Module	13
7 Center Wiper	13
8 Install Wiper Arm	14
9 Factory-Installed Power Module Seal	15
10 Attach the Enclosure Unit to the Power Module	15
11 Set the Tilt Position	16
12 Install the Sun Shroud	17
13 Remove Back Cap of Camera Enclosure	18
14 Remove or Install Camera Module	18
15 Install Camera Module	19
16 Center Wiper	19

List of Tables

A P Protocol Receiver Address	8
B D Protocol Receiver Address	8

Important Safety Instructions

1. Read these instructions.
2. Keep these instructions.
3. Heed all warnings.
4. Follow all instructions.
5. Do not block any ventilation openings. Install in accordance with the manufacturer's instructions.
6. To reduce the risk of ignition of hazardous atmospheres, disconnect the equipment from the supply circuit before opening. Keep assembly tightly closed when in operation.
7. The maximum ambient temperature range is -76° to 140°F (-60° to 60°C).
8. Only use attachments/accessories specified by the manufacturer.
9. Refer all servicing to qualified service personnel. Servicing is required when the apparatus has been damaged in any way, such as power-supply cord or plug is damaged, liquid has been spilled or objects have fallen into the apparatus, the apparatus has been exposed to rain or moisture, does not operate normally, or has been dropped.
10. Installation should be done only by qualified personnel and conform to all local codes.
11. Unless the unit is specifically marked as a NEMA Type 3, 3R, 3S, 4, 4X, 6, or 6P enclosure, it is designed for indoor use only and it must not be installed where exposed to rain and moisture.
12. Use only installation methods and materials capable of supporting four times the maximum specified load.
13. Use stainless steel hardware to fasten the mount to outdoor surfaces.
14. AN ALL-POLE MAINS SWITCH with a contact separation of at least 3 mm in each pole shall be incorporated in the electrical installation of the building.
15. A readily accessible disconnect device shall be incorporated in the building installation wiring.
16. **CAUTION:** These servicing instructions are for use by qualified service personnel only. To reduce the risk of electric shock do not perform any servicing other than that contained in the operating instructions unless you are qualified to do so.
17. Only use replacement parts recommended by Pelco.
18. A certified flameproof, "d," sealing device such as a stopping box with setting compound shall be provided, either in the flameproof enclosure or immediately at the entrance thereto.
19. For ambient temperatures below 14°F (-10°C) use field wiring suitable for both minimum and maximum ambient temperature.

The product and/or manual may bear the following marks:



WARNING: This symbol indicates that dangerous voltage constituting a risk of electric shock is present within this unit.



This symbol indicates that there are important operating and maintenance instructions in the literature accompanying this unit.



WARNING: HAZARDOUS MOVING PARTS. KEEP FINGERS AND OTHER BODY PARTS AWAY.



WARNING: To reduce the risk of ignition of hazardous atmospheres, disconnect the equipment from the supply circuit before opening. Keep assembly tightly closed when operating.



WARNING: To reduce the risk of ignition of hazardous atmospheres, conduit runs must have a sealing fitting connected within 2 inches of the enclosure.



TO REDUCE THE RISK OF IGNITION DO NOT OPEN WHEN AN EXPLOSIVE GAS ATMOSPHERE MAY BE PRESENT.

CAUTION:
RISK OF ELECTRIC SHOCK. DO NOT OPEN.

Getting Started

Thank you for purchasing Pelco's ExSite® EHXM Series explosionproof system. This manual includes instructions for installing all the components of the system. Once the system installation is complete, refer to the operation/programming manual for instructions on how to operate and program your system.

METHODS OF INSTALLATION

The system can be installed in a standard or inverted position. When installed for inverted operation, the camera orientation and controller functions are reconfigured for normal operation through the system's software. Hardware adjustment is not required for inverted operation. Refer to Figure 1 for installation methods.

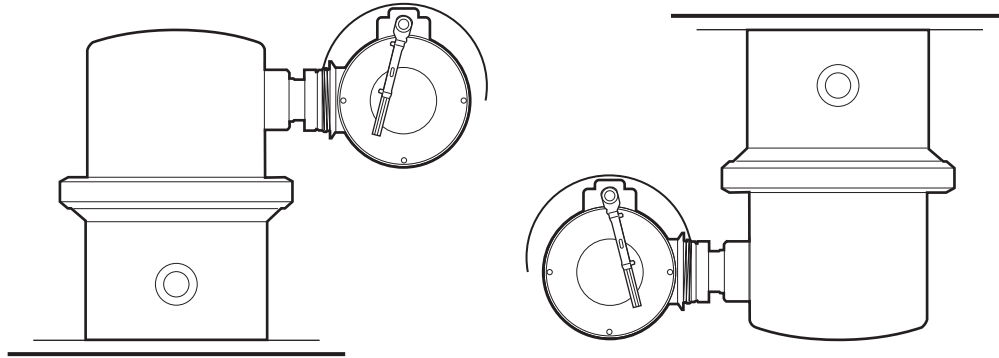

Figure 1. Methods of Installation



WARNINGS:

- Total weight of the system is 34.7 lb (15.71 kg). Use caution when lifting and assembling the enclosure component on the power module. It is recommended that non-slip gloves be worn during installation.
- Do not turn the body of the enclosure more than 200° in either direction or damage to the power module cable may occur.

Install the Power Module

Attach the power module to the mounting surface. Use only installation methods and materials capable of supporting four times the maximum specified load of the system (140 lb/63.5 kg).

NOTE: If required, install the optional TXB translator, fiber module, or UTP board before installing the power module. Refer to the installation instructions supplied with the TXB translator, fiber module, or UTP board for installation instructions.

To install the power module, refer to Figure 2 and do the following:

1. Make sure the threads of the power module and the threads of the supplied M10 x 16 mm stainless steel bolts are free of dirt and debris.
2. Apply a generous amount of thread locking compound (supplied) to the threads of the power module and the threads of the stainless steel bolts.
3. Face the conduit fitting of the power module towards the mating conduit fitting of the installation.
4. Use the supplied 8 mm Allen wrench to secure the power module to the mounting surface with four M10 x 16 mm stainless steel bolts and lock washers. Tighten the bolts to 25 to 27 ft-lb (34 to 37 Nm). The thread locking compound supplied must cure for one hour. Allow for this cure period prior to completing the installation.

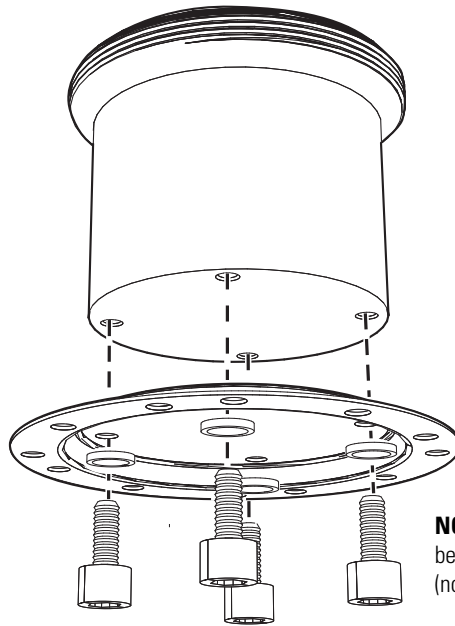

NOTE: Figure 2 shows the power module being installed on a PXM100 pedestal mount (not supplied).

Figure 2. Attach Power Module to Mounting Surface

CONNECT WIRING

⚠ DANGER: Do not connect the power module to a supply circuit unless all ExSite system components (enclosure, camera module, and power module) are installed.

Refer to the following information to connect the wires and cables as required.

⚠ WARNING: When installing this unit, provide access to the communication wires (TX+ and TX-) to allow connection to the system for future software upgrades. Connectors must be installed so that the integrity of the hazardous location is maintained.

These communication wires are required even if the system uses Coaxitron® control.

Maximum wire distance for RS-422 data wires is 4,000 ft (1,219 m).

NOTES:

- Relay 3 is allocated specifically for an external washer (not supplied by Pelco).
- All relays are specified for 32 VDC, 0.5 A.
- Wiring/cable for UTP and fiber optic are not provided on the wire harness. The installer must provide UTP and fiber optic connections.

Configuration of Wire Harness

Wire Color	Function
White/Orange	TX+
White/Blue	TX-
Red	RX+
Green	RX-
Violet/White	Relay 3 NC (washer only)
White/Red	Relay 3 COM (washer only)
Green/Black	Relay 3 NO (washer only)
Gray/White	Relay 2 NC
Yellow	Relay 2 COM
Violet	Relay 2 NO
Brown	Relay 1 NC
Gray	Relay 1 COM
White/Yellow/Black	Relay 1 NO
White/Black/Green	Alarm COM
White/Red/Black	Alarm 7
White/Brown/Black	Alarm 6
Orange	Alarm 5
White/Orange/Black	Alarm 4
White/Blue/Black	Alarm 3
White/Brown	Alarm 2
White/Black	Alarm 1

Video Coaxial Cable Requirements

Cable Type*	Maximum Distance
RG59/U	750 ft (229 m)
RG6/U	1,000 ft (305 m)
RG11/U	1,500 ft (457 m)

*Cable requirements:
 75-ohm impedance
 All-copper center conductor
 All-copper braided shield with 95% braid coverage

Power Connections 24 VAC

Wire Color	Function
Red	AC Hi
Black	AC Low

Power Connections 100-240 VAC

Wire Color	Function
Black	AC Hi
White	AC Low
Green/Yellow	Earth Ground

Wiring Distances

The following are the recommended maximum distances for 24 VAC and 100-240 VAC applications and are calculated with a 10 percent voltage drop. (Ten percent is generally the maximum allowable voltage drop for AC-powered devices.)

Power	Wire Gauge			
	18 (1.0 mm ²)	16 (1.5 mm ²)	14 (2.5 mm ²)	12 (3.5 mm ²)
24 VAC	27 ft (8 m)	43 ft (13 m)	69 ft (21 m)	110 ft (33 m)
100-240 VAC	75 ft (23 m)	120 ft (36 m)	190 ft (58 m)	310 ft (94 m)

NOTE: Power consumption is 120 VA per unit. Use a power source with a minimum of 150 VA.

DIP SWITCH SETTINGS

Configure the receiver address, termination, and baud setting for the system. The DIP switches to configure these settings are located on the top of the power module.

NOTE: No DIP switch settings are required for Coaxitron control.

Figure 3 shows the default settings for the DIP switches. Refer to the following to configure the ExSite system settings.

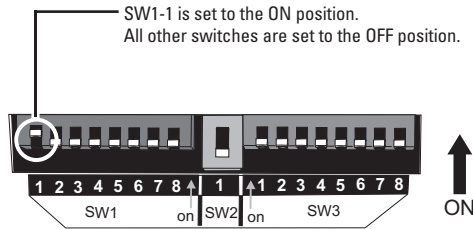

Figure 3. Default DIP Switch Settings

PROTOCOL SETTINGS

The ExSite system automatically detects the type of protocol. No switch settings are required to set Coaxitron or RS-422 P and D protocols.

RECEIVER ADDRESS SETTINGS (SW1)

The default address is 2 for P protocol. Refer to Table A for address settings that use P protocol. Maximum number of receivers is 32.

The default address is 1 for D protocol. Refer to Table B for address settings that use D protocol. Maximum number of receivers is 254.

TERMINATION SETTING (SW2)

When connecting more than one ExSite system to a single controller, terminate the unit farthest from the controller. Termination is required only for the last unit in the series. The unit is shipped from the factory in the unterminated OFF position. To terminate the unit, set the SW2 switch to the ON position.

BAUD SETTINGS (SW3)

Pelco's D-type controllers are set for 2400 baud. The default setting for the unit is 2400 baud. If you are using a Pelco D-type controller, do not reset the SW3 switches.

P-type controllers can operate at 2400, 4800, and 9600 baud. Set the SW3 switches (6, 7, and 8), located on the top of the power module, to the same baud as the P-type controller.

Switch Settings for SW3

Switch Number	SW3-6	SW3-7	SW3-8
2400 Baud	Off	Off	Off
4800 Baud	On	Off	Off
9600 Baud	Off	On	Off

Table A. P Protocol Receiver Address

ADDRESS	SWITCH SETTING							
	SW1-1	SW1-2	SW1-3	SW1-4	SW1-5	SW1-6	SW1-7	SW1-8
1	OFF	OFF	OFF	OFF	OFF	OFF	OFF	OFF
2	ON	OFF	OFF	OFF	OFF	OFF	OFF	OFF
3	OFF	ON	OFF	OFF	OFF	OFF	OFF	OFF
4	ON	ON	OFF	OFF	OFF	OFF	OFF	OFF
5	OFF	OFF	ON	OFF	OFF	OFF	OFF	OFF
6	ON	OFF	ON	OFF	OFF	OFF	OFF	OFF
7	OFF	ON	ON	OFF	OFF	OFF	OFF	OFF
8	ON	ON	ON	OFF	OFF	OFF	OFF	OFF
9	OFF	OFF	OFF	ON	OFF	OFF	OFF	OFF
10	ON	OFF	OFF	ON	OFF	OFF	OFF	OFF
11	OFF	ON	OFF	ON	OFF	OFF	OFF	OFF
12	ON	ON	OFF	ON	OFF	OFF	OFF	OFF
13	OFF	OFF	ON	ON	OFF	OFF	OFF	OFF
14	ON	OFF	ON	ON	OFF	OFF	OFF	OFF
15	OFF	ON	ON	ON	OFF	OFF	OFF	OFF
16	ON	ON	ON	ON	OFF	OFF	OFF	OFF

ADDRESS	SWITCH SETTING							
	SW1-1	SW1-2	SW1-3	SW1-4	SW1-5	SW1-6	SW1-7	SW1-8
17	OFF	OFF	OFF	OFF	ON	OFF	OFF	OFF
18	ON	OFF	OFF	OFF	ON	OFF	OFF	OFF
19	OFF	ON	OFF	OFF	ON	OFF	OFF	OFF
20	ON	ON	OFF	OFF	ON	OFF	OFF	OFF
21	OFF	OFF	ON	OFF	ON	OFF	OFF	OFF
22	ON	OFF	ON	OFF	ON	OFF	OFF	OFF
23	OFF	ON	ON	OFF	ON	OFF	OFF	OFF
24	ON	ON	ON	OFF	ON	OFF	OFF	OFF
25	OFF	OFF	OFF	ON	ON	OFF	OFF	OFF
26	ON	OFF	OFF	ON	ON	OFF	OFF	OFF
27	OFF	ON	OFF	ON	ON	OFF	OFF	OFF
28	ON	ON	OFF	ON	ON	OFF	OFF	OFF
29	OFF	OFF	ON	ON	ON	OFF	OFF	OFF
30	ON	OFF	ON	ON	ON	OFF	OFF	OFF
31	OFF	ON	ON	ON	ON	OFF	OFF	OFF
32	ON	ON	ON	ON	ON	OFF	OFF	OFF

Table B. D Protocol Receiver Address

ADDRESS	SWITCH SETTING							
	SW1-1	SW1-2	SW1-3	SW1-4	SW1-5	SW1-6	SW1-7	SW1-8
1	ON	OFF	OFF	OFF	OFF	OFF	OFF	OFF
2	OFF	ON	OFF	OFF	OFF	OFF	OFF	OFF
3	ON	ON	OFF	OFF	OFF	OFF	OFF	OFF
4	OFF	OFF	ON	OFF	OFF	OFF	OFF	OFF
5	ON	OFF	ON	OFF	OFF	OFF	OFF	OFF
6	OFF	ON	ON	OFF	OFF	OFF	OFF	OFF
7	ON	ON	ON	OFF	OFF	OFF	OFF	OFF
8	OFF	OFF	OFF	ON	OFF	OFF	OFF	OFF
9	ON	OFF	OFF	ON	OFF	OFF	OFF	OFF
10	OFF	ON	OFF	ON	OFF	OFF	OFF	OFF
11	ON	ON	OFF	ON	OFF	OFF	OFF	OFF
12	OFF	OFF	ON	ON	OFF	OFF	OFF	OFF
13	ON	OFF	ON	ON	OFF	OFF	OFF	OFF
14	OFF	ON	ON	ON	OFF	OFF	OFF	OFF
15	ON	ON	ON	ON	OFF	OFF	OFF	OFF
16	OFF	OFF	OFF	OFF	ON	OFF	OFF	OFF
17	ON	OFF	OFF	OFF	ON	OFF	OFF	OFF
18	OFF	ON	OFF	OFF	ON	OFF	OFF	OFF
19	ON	ON	OFF	OFF	ON	OFF	OFF	OFF
20	OFF	OFF	ON	OFF	ON	OFF	OFF	OFF
21	ON	OFF	ON	OFF	ON	OFF	OFF	OFF
22	OFF	ON	ON	OFF	ON	OFF	OFF	OFF
23	ON	ON	ON	OFF	ON	OFF	OFF	OFF
24	OFF	OFF	OFF	ON	ON	OFF	OFF	OFF

ADDRESS	SWITCH SETTING							
	SW1-1	SW1-2	SW1-3	SW1-4	SW1-5	SW1-6	SW1-7	SW1-8
25	ON	OFF	OFF	ON	ON	OFF	OFF	OFF
26	OFF	ON	OFF	ON	ON	OFF	OFF	OFF
27	ON	ON	OFF	ON	ON	OFF	OFF	OFF
28	OFF	OFF	ON	ON	ON	OFF	OFF	OFF
29	ON	OFF	ON	ON	ON	OFF	OFF	OFF
30	OFF	ON	ON	ON	ON	OFF	OFF	OFF
31	ON	ON	ON	ON	ON	OFF	OFF	OFF
32	OFF	OFF	OFF	OFF	OFF	ON	OFF	OFF
33	ON	OFF	OFF	OFF	OFF	ON	OFF	OFF
34	OFF	ON	OFF	OFF	OFF	ON	OFF	OFF
35	ON	ON	OFF	OFF	OFF	ON	OFF	OFF
36	OFF	OFF	ON	OFF	OFF	ON	OFF	OFF
37	ON	OFF	ON	OFF	OFF	ON	OFF	OFF
38	OFF	ON	ON	OFF	OFF	ON	OFF	OFF
39	ON	ON	ON	OFF	OFF	ON	OFF	OFF
40	OFF	OFF	OFF	ON	OFF	ON	OFF	OFF
41	ON	OFF	OFF	ON	OFF	ON	OFF	OFF
42	OFF	ON	OFF	ON	OFF	ON	OFF	OFF
43	ON	ON	OFF	ON	OFF	ON	OFF	OFF
44	OFF	OFF	ON	ON	OFF	ON	OFF	OFF
45	ON	OFF	ON	ON	OFF	ON	OFF	OFF
46	OFF	ON	ON	ON	OFF	ON	OFF	OFF
47	ON	ON	ON	ON	OFF	ON	OFF	OFF
48	OFF	OFF	OFF	OFF	ON	ON	OFF	OFF

(Continued on next page)

Table B. D Protocol Receiver Address (Continued)

ADDRESS	SWITCH SETTING							
	SW1-1	SW1-2	SW1-3	SW1-4	SW1-5	SW1-6	SW1-7	SW1-8
49	ON	OFF	OFF	OFF	ON	ON	OFF	OFF
50	OFF	ON	OFF	OFF	ON	ON	OFF	OFF
51	ON	ON	OFF	OFF	ON	ON	OFF	OFF
52	OFF	OFF	ON	OFF	ON	ON	OFF	OFF
53	ON	OFF	ON	OFF	ON	ON	OFF	OFF
54	OFF	ON	ON	OFF	ON	ON	OFF	OFF
55	ON	ON	ON	OFF	ON	ON	OFF	OFF
56	OFF	OFF	OFF	ON	ON	ON	OFF	OFF
57	ON	OFF	OFF	ON	ON	ON	OFF	OFF
58	OFF	ON	OFF	ON	ON	ON	OFF	OFF
59	ON	ON	OFF	ON	ON	ON	OFF	OFF
60	OFF	OFF	ON	ON	ON	ON	OFF	OFF
61	ON	OFF	ON	ON	ON	ON	OFF	OFF
62	OFF	ON	ON	ON	ON	ON	OFF	OFF
63	ON	ON	ON	ON	ON	ON	OFF	OFF
64	OFF	OFF	OFF	OFF	OFF	OFF	ON	OFF
65	ON	OFF	OFF	OFF	OFF	OFF	ON	OFF
66	OFF	ON	OFF	OFF	OFF	OFF	ON	OFF
67	ON	ON	OFF	OFF	OFF	OFF	ON	OFF
68	OFF	OFF	ON	OFF	OFF	OFF	ON	OFF
69	ON	OFF	ON	OFF	OFF	OFF	ON	OFF
70	OFF	ON	ON	OFF	OFF	OFF	ON	OFF
71	ON	ON	ON	OFF	OFF	OFF	ON	OFF
72	OFF	OFF	OFF	ON	OFF	OFF	ON	OFF
73	ON	OFF	OFF	ON	OFF	OFF	ON	OFF
74	OFF	ON	OFF	ON	OFF	OFF	ON	OFF
75	ON	ON	OFF	ON	OFF	OFF	ON	OFF
76	OFF	OFF	ON	ON	OFF	OFF	ON	OFF
77	ON	OFF	ON	ON	OFF	OFF	ON	OFF
78	OFF	ON	ON	ON	OFF	OFF	ON	OFF
79	ON	ON	ON	ON	OFF	OFF	ON	OFF
80	OFF	OFF	OFF	OFF	ON	OFF	ON	OFF
81	ON	OFF	OFF	OFF	ON	OFF	ON	OFF
82	OFF	ON	OFF	OFF	ON	OFF	ON	OFF
83	ON	ON	OFF	OFF	ON	OFF	ON	OFF
84	OFF	OFF	ON	OFF	ON	OFF	ON	OFF
85	ON	OFF	ON	OFF	ON	OFF	ON	OFF
86	OFF	ON	ON	OFF	ON	OFF	ON	OFF
87	ON	ON	ON	OFF	ON	OFF	ON	OFF
88	OFF	OFF	OFF	ON	ON	OFF	ON	OFF
89	ON	OFF	OFF	ON	ON	OFF	ON	OFF
90	OFF	ON	OFF	ON	ON	OFF	ON	OFF
91	ON	ON	OFF	ON	ON	OFF	ON	OFF
92	OFF	OFF	ON	ON	ON	OFF	ON	OFF
93	ON	OFF	ON	ON	ON	OFF	ON	OFF
94	OFF	ON	ON	ON	ON	OFF	ON	OFF
95	ON	ON	ON	ON	ON	OFF	ON	OFF

ADDRESS	SWITCH SETTING							
	SW1-1	SW1-2	SW1-3	SW1-4	SW1-5	SW1-6	SW1-7	SW1-8
96	OFF	OFF	OFF	OFF	OFF	ON	ON	OFF
97	ON	OFF	OFF	OFF	OFF	ON	ON	OFF
98	OFF	ON	OFF	OFF	OFF	ON	ON	OFF
99	ON	ON	OFF	OFF	OFF	ON	ON	OFF
100	OFF	OFF	ON	OFF	OFF	ON	ON	OFF
101	ON	OFF	ON	OFF	OFF	ON	ON	OFF
102	OFF	ON	ON	OFF	OFF	ON	ON	OFF
103	ON	ON	ON	OFF	OFF	ON	ON	OFF
104	OFF	OFF	OFF	ON	OFF	ON	ON	OFF
105	ON	OFF	OFF	ON	OFF	ON	ON	OFF
106	OFF	ON	OFF	ON	OFF	ON	ON	OFF
107	ON	ON	OFF	ON	OFF	ON	ON	OFF
108	OFF	OFF	ON	ON	OFF	ON	ON	OFF
109	ON	OFF	ON	ON	OFF	ON	ON	OFF
110	OFF	ON	ON	ON	OFF	ON	ON	OFF
111	ON	ON	ON	ON	OFF	ON	ON	OFF
112	OFF	OFF	OFF	OFF	ON	ON	ON	OFF
113	ON	OFF	OFF	OFF	ON	ON	ON	OFF
114	OFF	ON	OFF	OFF	ON	ON	ON	OFF
115	ON	ON	OFF	OFF	ON	ON	ON	OFF
116	OFF	OFF	ON	OFF	ON	ON	ON	OFF
117	ON	OFF	ON	OFF	ON	ON	ON	OFF
118	OFF	ON	ON	OFF	ON	ON	ON	OFF
119	ON	ON	ON	OFF	ON	ON	ON	OFF
120	OFF	OFF	OFF	ON	ON	ON	ON	OFF
121	ON	OFF	OFF	ON	ON	ON	ON	OFF
122	OFF	ON	OFF	ON	ON	ON	ON	OFF
123	ON	ON	OFF	ON	ON	ON	ON	OFF
124	OFF	OFF	ON	ON	ON	ON	ON	OFF
125	ON	OFF	ON	ON	ON	ON	ON	OFF
126	OFF	ON	ON	ON	ON	ON	ON	OFF
127	ON	ON	ON	ON	ON	ON	ON	OFF
128	OFF	OFF	OFF	OFF	OFF	OFF	OFF	ON
129	ON	OFF	OFF	OFF	OFF	OFF	OFF	ON
130	OFF	ON	OFF	OFF	OFF	OFF	OFF	ON
131	ON	ON	OFF	OFF	OFF	OFF	OFF	ON
132	OFF	OFF	ON	OFF	OFF	OFF	OFF	ON
133	ON	OFF	ON	OFF	OFF	OFF	OFF	ON
134	OFF	ON	ON	OFF	OFF	OFF	OFF	ON
135	ON	ON	ON	OFF	OFF	OFF	OFF	ON
136	OFF	OFF	OFF	ON	OFF	OFF	OFF	ON
137	ON	OFF	OFF	ON	OFF	OFF	OFF	ON
138	OFF	ON	OFF	ON	OFF	OFF	OFF	ON
139	ON	ON	OFF	ON	OFF	OFF	OFF	ON
140	OFF	OFF	ON	ON	OFF	OFF	OFF	ON
141	ON	OFF	ON	ON	OFF	OFF	OFF	ON
142	OFF	ON	ON	ON	OFF	OFF	OFF	ON

(Continued on next page)

Table B. D Protocol Receiver Address (Continued)

ADDRESS	SWITCH SETTING							
	SW1-1	SW1-2	SW1-3	SW1-4	SW1-5	SW1-6	SW1-7	SW1-8
143	ON	ON	ON	ON	OFF	OFF	OFF	ON
144	OFF	OFF	OFF	OFF	ON	OFF	OFF	ON
145	ON	OFF	OFF	OFF	ON	OFF	OFF	ON
146	OFF	ON	OFF	OFF	ON	OFF	OFF	ON
147	ON	ON	OFF	OFF	ON	OFF	OFF	ON
148	OFF	OFF	ON	OFF	ON	OFF	OFF	ON
149	ON	OFF	ON	OFF	ON	OFF	OFF	ON
150	OFF	ON	ON	OFF	ON	OFF	OFF	ON
151	ON	ON	ON	OFF	ON	OFF	OFF	ON
152	OFF	OFF	OFF	ON	ON	OFF	OFF	ON
153	ON	OFF	OFF	ON	ON	OFF	OFF	ON
154	OFF	ON	OFF	ON	ON	OFF	OFF	ON
155	ON	ON	OFF	ON	ON	OFF	OFF	ON
156	OFF	OFF	ON	ON	ON	OFF	OFF	ON
157	ON	OFF	ON	ON	ON	OFF	OFF	ON
158	OFF	ON	ON	ON	ON	OFF	OFF	ON
159	ON	ON	ON	ON	ON	OFF	OFF	ON
160	OFF	OFF	OFF	OFF	OFF	ON	OFF	ON
161	ON	OFF	OFF	OFF	OFF	ON	OFF	ON
162	OFF	ON	OFF	OFF	OFF	ON	OFF	ON
163	ON	ON	OFF	OFF	OFF	ON	OFF	ON
164	OFF	OFF	ON	OFF	OFF	ON	OFF	ON
165	ON	OFF	ON	OFF	OFF	ON	OFF	ON
166	OFF	ON	ON	OFF	OFF	ON	OFF	ON
167	ON	ON	ON	OFF	OFF	ON	OFF	ON
168	OFF	OFF	OFF	ON	OFF	ON	OFF	ON
169	ON	OFF	OFF	ON	OFF	ON	OFF	ON
170	OFF	ON	OFF	ON	OFF	ON	OFF	ON
171	ON	ON	OFF	ON	OFF	ON	OFF	ON
172	OFF	OFF	ON	ON	OFF	ON	OFF	ON
173	ON	OFF	ON	ON	OFF	ON	OFF	ON
174	OFF	ON	ON	ON	OFF	ON	OFF	ON
175	ON	ON	ON	ON	OFF	ON	OFF	ON
176	OFF	OFF	OFF	OFF	ON	ON	OFF	ON
177	ON	OFF	OFF	OFF	ON	ON	OFF	ON
178	OFF	ON	OFF	OFF	ON	ON	OFF	ON
179	ON	ON	OFF	OFF	ON	ON	OFF	ON
180	OFF	OFF	ON	OFF	ON	ON	OFF	ON
181	ON	OFF	ON	OFF	ON	ON	OFF	ON
182	OFF	ON	ON	OFF	ON	ON	OFF	ON
183	ON	ON	ON	OFF	ON	ON	OFF	ON
184	OFF	OFF	OFF	ON	ON	ON	OFF	ON
185	ON	OFF	OFF	ON	ON	ON	OFF	ON
186	OFF	ON	OFF	ON	ON	ON	OFF	ON
187	ON	ON	OFF	ON	ON	ON	OFF	ON
188	OFF	OFF	ON	ON	ON	ON	OFF	ON
189	ON	OFF	ON	ON	ON	ON	OFF	ON
190	OFF	ON	ON	ON	ON	ON	OFF	ON

ADDRESS	SWITCH SETTING							
	SW1-1	SW1-2	SW1-3	SW1-4	SW1-5	SW1-6	SW1-7	SW1-8
191	ON	ON	ON	ON	ON	ON	OFF	ON
192	OFF	OFF	OFF	OFF	OFF	OFF	ON	ON
193	ON	OFF	OFF	OFF	OFF	OFF	ON	ON
194	OFF	ON	OFF	OFF	OFF	OFF	ON	ON
195	ON	ON	OFF	OFF	OFF	OFF	ON	ON
196	OFF	OFF	ON	OFF	OFF	OFF	ON	ON
197	ON	OFF	ON	OFF	OFF	OFF	ON	ON
198	OFF	ON	ON	OFF	OFF	OFF	ON	ON
199	ON	ON	ON	OFF	OFF	OFF	ON	ON
200	OFF	OFF	OFF	ON	OFF	OFF	ON	ON
201	ON	OFF	OFF	ON	OFF	OFF	ON	ON
202	OFF	ON	OFF	ON	OFF	OFF	ON	ON
203	ON	ON	OFF	ON	OFF	OFF	ON	ON
204	OFF	OFF	ON	ON	OFF	OFF	ON	ON
205	ON	OFF	ON	ON	OFF	OFF	ON	ON
206	OFF	ON	ON	ON	OFF	OFF	ON	ON
207	ON	ON	ON	ON	OFF	OFF	ON	ON
208	OFF	OFF	OFF	OFF	ON	OFF	ON	ON
209	ON	OFF	OFF	OFF	ON	OFF	ON	ON
210	OFF	ON	OFF	OFF	ON	OFF	ON	ON
211	ON	ON	OFF	OFF	ON	OFF	ON	ON
212	OFF	OFF	ON	OFF	ON	OFF	ON	ON
213	ON	OFF	ON	OFF	ON	OFF	ON	ON
214	OFF	ON	ON	OFF	ON	OFF	ON	ON
215	ON	ON	ON	OFF	ON	OFF	ON	ON
216	OFF	OFF	OFF	ON	ON	OFF	ON	ON
217	ON	OFF	OFF	ON	ON	OFF	ON	ON
218	OFF	ON	OFF	ON	ON	OFF	ON	ON
219	ON	ON	OFF	ON	ON	OFF	ON	ON
220	OFF	OFF	ON	ON	ON	OFF	ON	ON
221	ON	OFF	ON	ON	ON	OFF	ON	ON
222	OFF	ON	ON	ON	ON	OFF	ON	ON
223	ON	ON	ON	ON	ON	OFF	ON	ON
224	OFF	OFF	OFF	OFF	OFF	ON	ON	ON
225	ON	OFF	OFF	OFF	OFF	ON	ON	ON
226	OFF	ON	OFF	OFF	OFF	ON	ON	ON
227	ON	ON	OFF	OFF	OFF	ON	ON	ON
228	OFF	OFF	ON	OFF	OFF	ON	ON	ON
229	ON	OFF	ON	OFF	OFF	ON	ON	ON
230	OFF	ON	ON	OFF	OFF	ON	ON	ON
231	ON	ON	ON	OFF	OFF	ON	ON	ON
232	OFF	OFF	OFF	ON	OFF	ON	ON	ON
233	ON	OFF	OFF	ON	OFF	ON	ON	ON
234	OFF	ON	OFF	ON	OFF	ON	ON	ON
235	ON	ON	OFF	ON	OFF	ON	ON	ON
236	OFF	OFF	ON	ON	OFF	ON	ON	ON
237	ON	OFF	ON	ON	OFF	ON	ON	ON
238	OFF	ON	ON	ON	OFF	ON	ON	ON

(Continued on next page)

Table B. D Protocol Receiver Address (Continued)

ADDRESS	SWITCH SETTING							
	SW1-1	SW1-2	SW1-3	SW1-4	SW1-5	SW1-6	SW1-7	SW1-8
239	ON	ON	ON	ON	OFF	ON	ON	ON
240	OFF	OFF	OFF	OFF	ON	ON	ON	ON
241	ON	OFF	OFF	OFF	ON	ON	ON	ON
242	OFF	ON	OFF	OFF	ON	ON	ON	ON
243	ON	ON	OFF	OFF	ON	ON	ON	ON
244	OFF	OFF	ON	OFF	ON	ON	ON	ON
245	ON	OFF	ON	OFF	ON	ON	ON	ON
246	OFF	ON	ON	OFF	ON	ON	ON	ON

ADDRESS	SWITCH SETTING							
	SW1-1	SW1-2	SW1-3	SW1-4	SW1-5	SW1-6	SW1-7	SW1-8
247	ON	ON	ON	OFF	ON	ON	ON	ON
248	OFF	OFF	OFF	ON	ON	ON	ON	ON
249	ON	OFF	OFF	ON	ON	ON	ON	ON
250	OFF	ON	OFF	ON	ON	ON	ON	ON
251	ON	ON	OFF	ON	ON	ON	ON	ON
252	OFF	OFF	ON	ON	ON	ON	ON	ON
253	ON	OFF	ON	ON	ON	ON	ON	ON
254	OFF	ON	ON	ON	ON	ON	ON	ON

Install the Camera Module

To install the camera module, do the following:

1. Refer to Figure 4. Loosen the set screw at the back of the camera enclosure with the provided 1.5 mm Allen wrench.

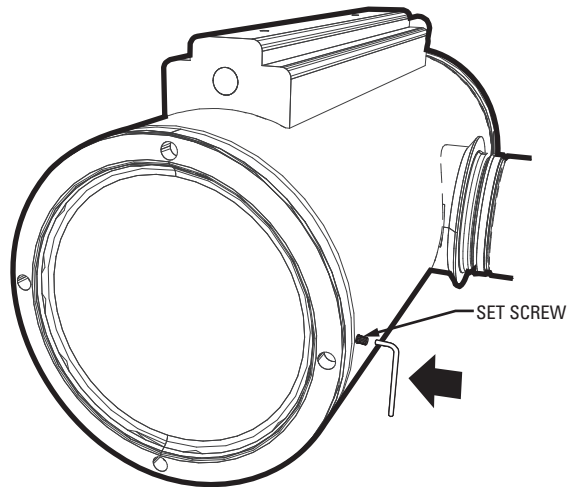

Figure 4. Loosen Set Screw

⚠ WARNING: To avoid thread damage carefully remove the back of the camera enclosure. Never use force to remove the back of the camera enclosure.

2. Use the supplied spanner wrench to loosen the back of the camera enclosure (refer to Figure 5). Once the back is loose, use your hands to continue to loosen it until it can be removed.

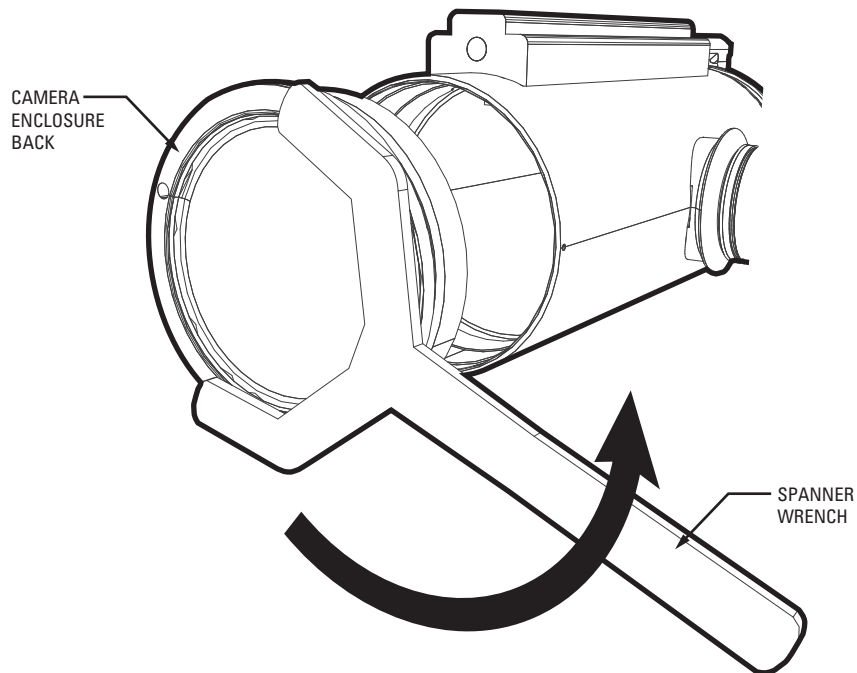

Figure 5. Remove Back Cap of Camera Enclosure

⚠ WARNING: Do not force the camera module into the camera enclosure.

- Slide the camera module into the camera enclosure. Refer to Figure 6 to position the camera module properly in the camera enclosure. Carefully mate the camera's power connector to the mating connector located inside the camera enclosure.

Models with a wiper: The tab located inside the camera enclosure must be pointing down before installing the camera module (refer to Figure 6). To position the tab, place the wiper, located at the front of the camera enclosure, in the center of the viewing window (refer to Figure 7).

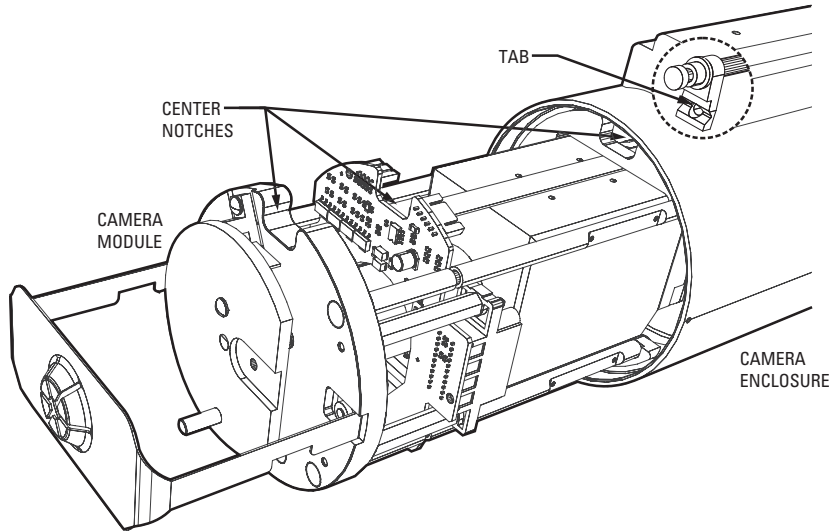

Figure 6. Install Camera Module

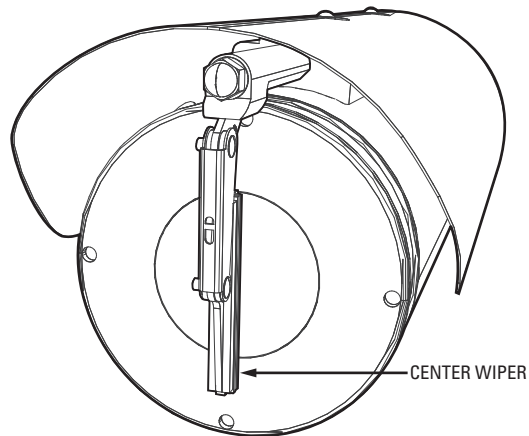

Figure 7. Center Wiper

4. **Models with a wiper:** Refer to Figure 8 and do the following to install the arm of the wiper:
 - a. Place the supplied green bushing on the stud located behind the handle of the camera module. The bushing should be in the same orientation as shown in Figure 8.
 - b. Install the wiper arm. Place the ridge of the arm in the notch of the camera enclosure tab and the slot of the arm over the green bushing.
5. Secure the camera module (and wiper) with the supplied 8-32 Phillips flat head screw (refer to Figure 8).

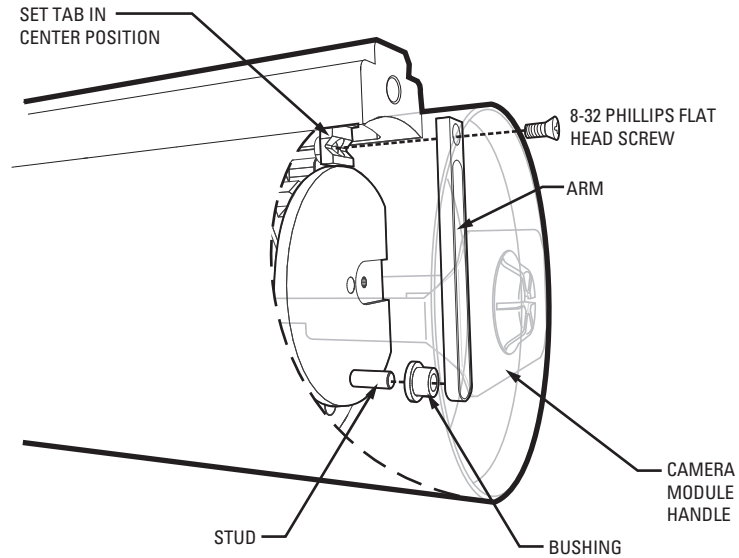

Figure 8. Install Wiper Arm



WARNINGS:

- To avoid thread damage carefully install the back cap to the camera enclosure.
- Never force the back cap onto the end of the camera enclosure.
- When installation is completed there should be no gap between the back cap and the camera enclosure.

6. Reinstall the back cap on the enclosure by doing the following:
 - a. Use your hands to turn the back cap clockwise until you can no longer turn it with your hands. The back cap should turn easily until it comes in contact with the O-ring. If it does not turn easily the threads are not aligned and thread damage will occur.
 - b. Continue tightening the back cap with the supplied spanner wrench. There should be no gap between the back cap and the enclosure when the back cap is tightened and properly installed.
 - c. Once the back cap is installed, secure the back cap with the set screw using the supplied 1.5 mm Allen wrench.

Install the Enclosure and Set Pan Position

1. Check for proper seating of the power module seal. Make sure the seal is fully seated in the groove on the top of the power module.

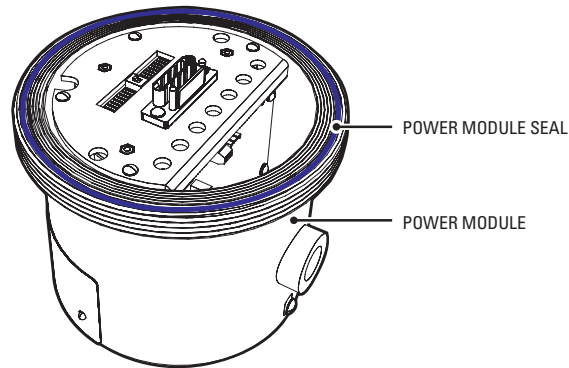

Figure 9. Factory-Installed Power Module Seal

⚠ WARNING: Use caution when attaching the enclosure unit to the power module. If the grooves on the top of the power module are damaged, the integrity of the unit could be compromised.

2. Refer to Figure 10 and attach the enclosure unit to the power module. Align the pins of the enclosure unit with the holes of the power module. Carefully mate the enclosure connector to the power module connector.

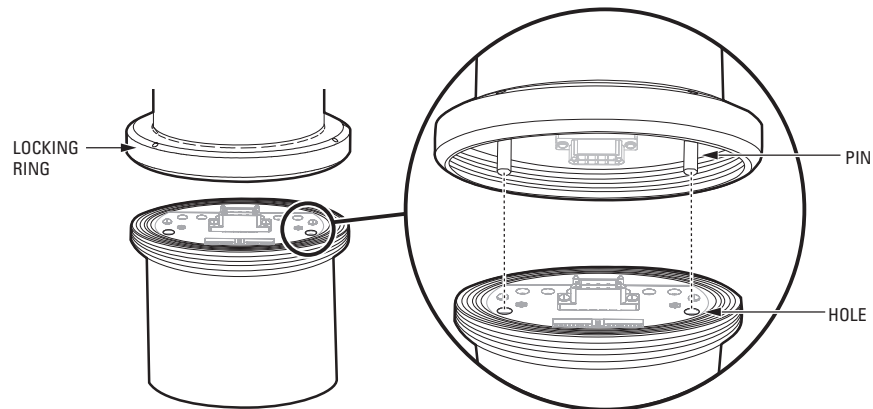

Figure 10. Attach the Enclosure Unit to the Power Module

⚠ WARNINGS:

- Total weight of the enclosure component is 34.7 lb (15.71 kg). Use caution when lifting and assembling the pan and tilt component on the power module.
- The weight of the enclosure unit must be safely supported during installation.
- It is recommended that non-slip gloves be worn during installation.
- Avoid thread damage. Never use force when assembling and tightening the threaded components of the system.

3. Turn the body of the enclosure to the left or right to set the pan position of the unit.

⚠ WARNING: Do not turn the body of the enclosure more than 200° in either direction or damage to the internal power module cable may occur.

4. With your hands carefully thread the enclosure's locking ring on the threads of the power module until the threads are completely engaged.
5. Use the supplied spanner wrench to tighten the locking ring and fix the position of the enclosure. After the locking ring has been tightened, tap the end of the handle of the wrench with a hammer or the palm of your hand to ensure a secure fit. Make sure that the pan position is maintained when tightening the locking ring. Tighten the set screw of the locking ring with the supplied 2 mm Allen wrench to secure the locking ring.

Set the Tilt Angle of the Camera Module

1. Place a 41 mm open end or crescent wrench on the tilt locking nut and a 21 mm open end wrench on the tilt shaft (refer to Figure 11).

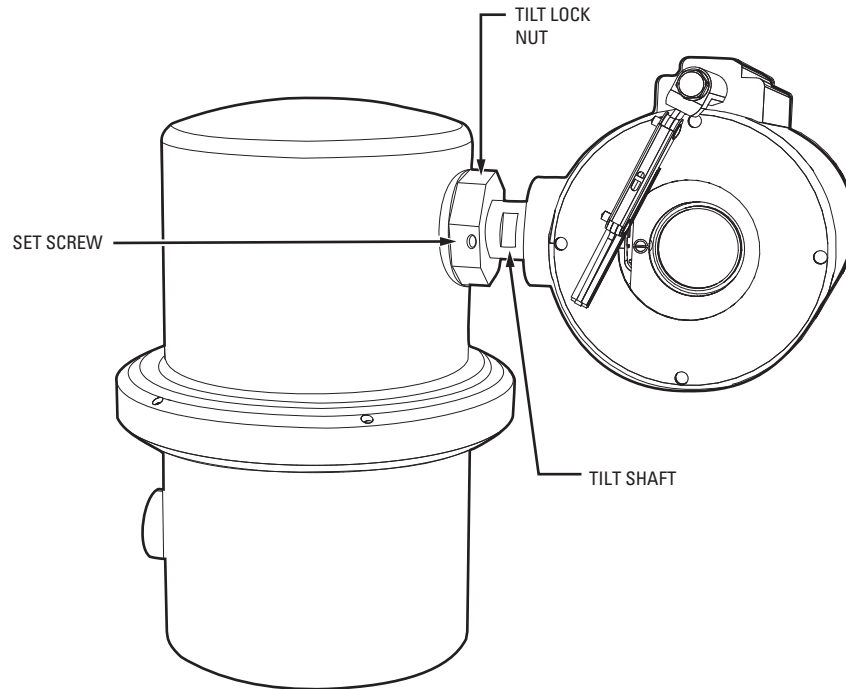

Figure 11. Set the Tilt Position

2. Hold the tilt shaft in position with the 21 mm wrench, and then turn the 41 mm wrench to loosen the tilt locking nut.
3. Adjust the tilt position of the camera module by moving the camera module up or down.
4. Continue to hold the tilt shaft with the 21 mm wrench and then tighten the tilt locking nut to set the tilt position of the camera module. Make sure the tilt position is maintained when tightening the locking ring. Tighten the set screw of the locking nut with the supplied 2 mm Allen wrench to secure the locking nut.

Install the Sun Shroud

1. Place the supplied nylon washers on the 6-32 Phillips pan head screws. Refer to Figure 12.
2. Align the mounting holes of the sun shroud with the holes on top of the camera enclosure.
3. Use the supplied nylon washers and screws to secure the sun shroud to the camera enclosure.

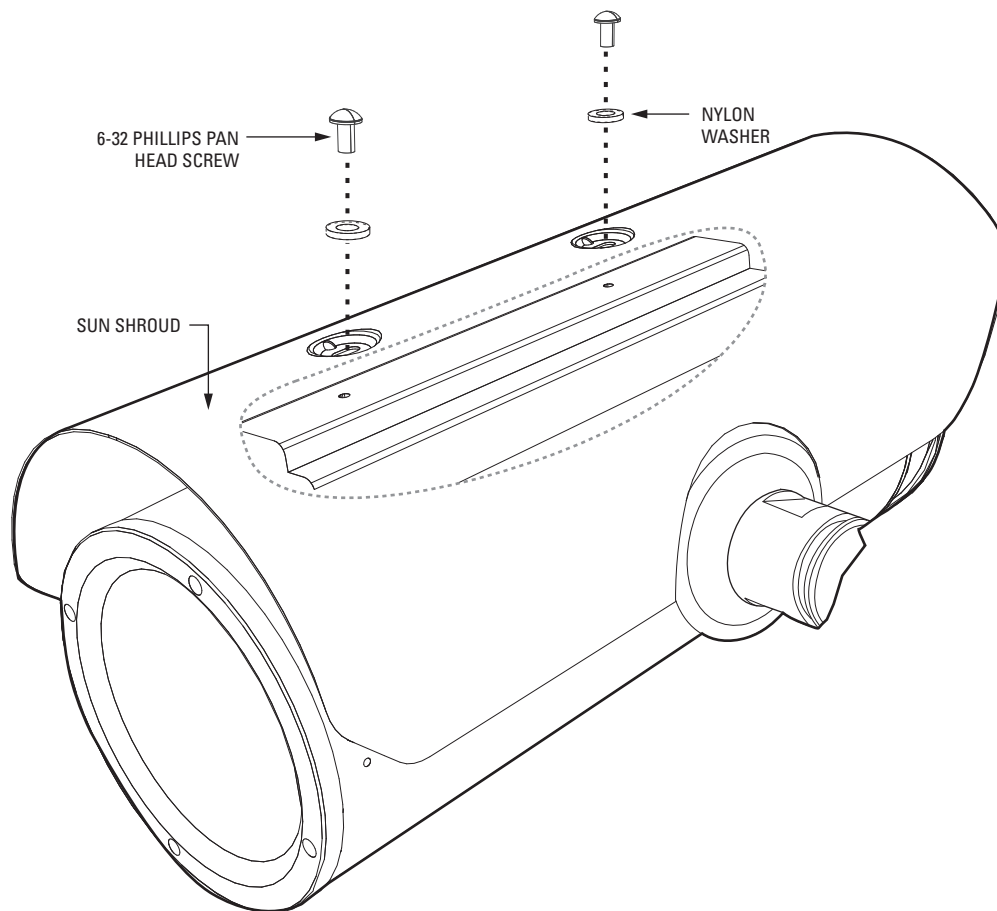

Figure 12. Install the Sun Shroud

Maintenance

CAMERA MODULE REPLACEMENT

⚠ DANGER: To reduce the risk of ignition of hazardous atmospheres, disconnect the equipment from the power supply before opening. Keep assembly tightly closed when operating.

To replace the camera module, do the following:

1. Remove the back cap of the camera enclosure. Refer to Figure 13 and do the following:
 - a. Loosen the set screw with a 1.5 mm Allen wrench.
 - b. Use the supplied spanner wrench to loosen the back cap of the camera enclosure. Once the back is loose, use your hands to continue to loosen it until it can be removed.

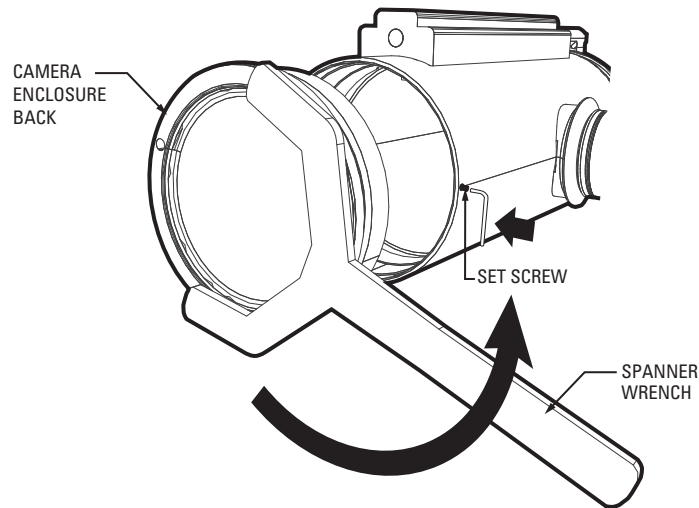

Figure 13. Remove Back Cap of Camera Enclosure

2. Remove the 8-32 Phillips flat head screw that secures the camera module inside the camera enclosure (refer to Figure 14).

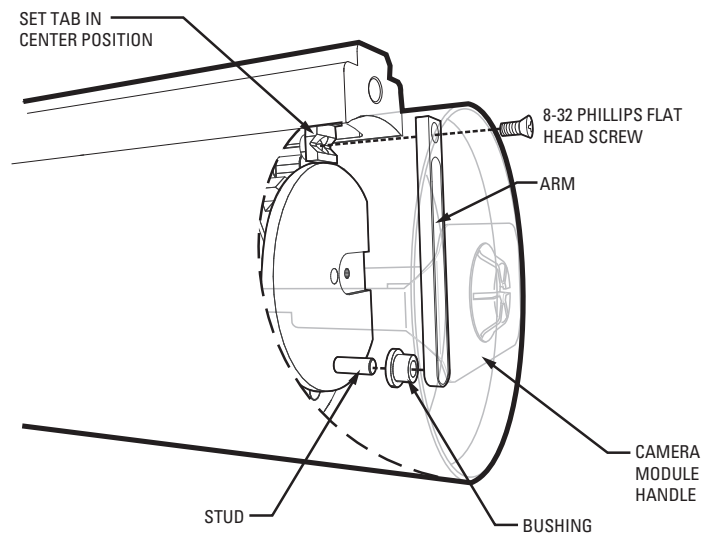

Figure 14. Remove or Install Camera Module

3. **Models with a wiper:** Remove the wiper arm and the green bushing from the unit (refer to Figure 14).
4. Slide the camera module out of the enclosure.

⚠ WARNING: Never force the camera module into the enclosure.

5. Install the new camera module by doing the following:

Slide the camera module into the camera enclosure. Refer to Figure 15 to position the camera module properly in the camera enclosure. Carefully mate the camera's power connector to the mating connector located inside the camera enclosure.

Models with a wiper: The tab located inside the enclosure must be pointing down before installing the camera module (refer to Figure 15). To position the tab, place the wiper, located at the front of the camera enclosure, in the center of the viewing window (refer to Figure 16).

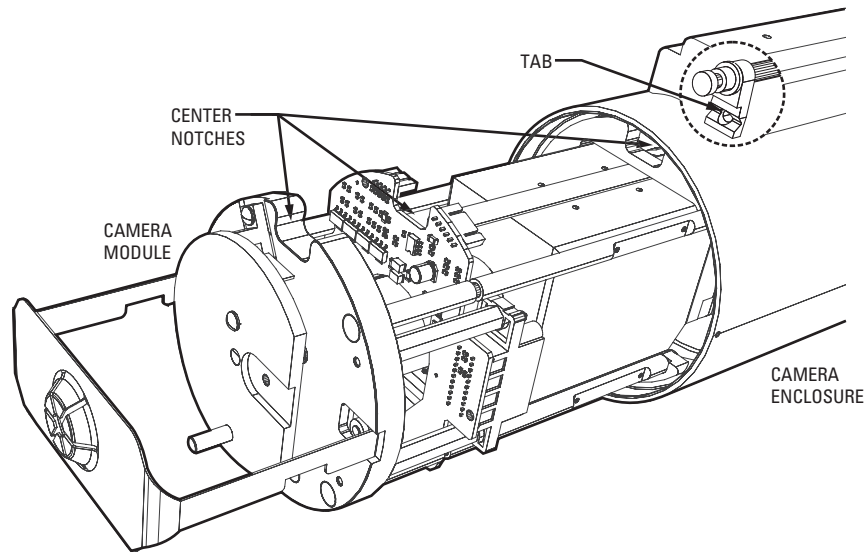

Figure 15. Install Camera Module

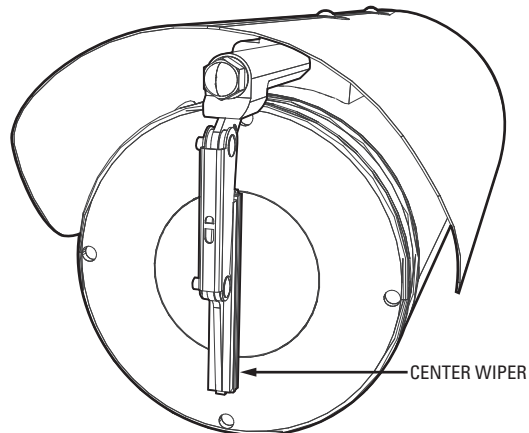

Figure 16. Center Wiper

6. **Models with a wiper:** Refer to Figure 14 and do the following to reinstall the arm of the wiper:
 - a. Reinstall the green bushing on the stud located behind the handle of the camera module.
 - b. Reinstall the wiper arm. Place the ridge of the arm in the notch of the camera enclosure tab and the slot of the arm over the green bushing.
7. Secure the camera module and the wiper arm with the 8-32 Phillips flat head screw (refer to Figure 14).



WARNINGS:

- To avoid thread damage, carefully install the back cap to the enclosure.
 - Never force the back cap onto the end of the enclosure.
 - When installation is completed, there should be no gap between the back cap and the camera enclosure.
8. Reinstall the back cap on the camera enclosure by doing the following:
 - a. Use your hands to turn the back cap clockwise until you can no longer turn it with your hands. The back cap should turn easily until it comes in contact with the O-ring. If it does not turn easily, the threads are not aligned and thread damage will occur.
 - b. Continue tightening the back cap with the supplied spanner wrench. There should be no gap between the back cap and the camera enclosure when the back cap is tightened and properly installed.
 - c. After the back cap is installed, secure the back cap with the set screw using a 1.5 mm Allen wrench.

Specifications

ELECTRICAL

Input Voltage	24 VAC or 100-240 VAC, 50/60 Hz
Input Voltage Range	±10%
Power Consumption	Maximum 60 W (120 VA) per system
Heater and Defroster	Microprocessor controlled
Electrical Connections	6-foot wire harness with connections for power, video, data control, alarm inputs, and auxiliary outputs

MECHANICAL

Cable Entry	One 0.75-inch (1.91 cm) NPT threaded opening
-------------	--

GENERAL

Construction	316L stainless steel
Finish	Electropolish
Viewing Window	0.50-inch (12.7 mm) thick, soda-lime tempered glass
Operating Temperature	-76° to 140°F (-60° to 60°C)
Unit Weight	34.7 lb (15.71 kg)
Effective Projected Area (EPA)	97.3 square inches

CERTIFICATIONS

Class I, Groups A, B, C, and D
 Class II, Groups E, F, G, T5
 Class I, Zone 1, AEx d IIC, Ex d IIC, T5
 BR-Ex d IIC, T5, IP66
 04/UL-BRAE-0027
 IECEx UL 04.0010X, Ex d IIC, T5
 DEMKO 04 ATEX 0413858
 Ⓒ 0539 Ⓔ II 2 G Ex d IIC, T5
 Ⓔ II 2 D Ex tD A21 IP66 T105°C
 (Tamb -60°C to +60°C)

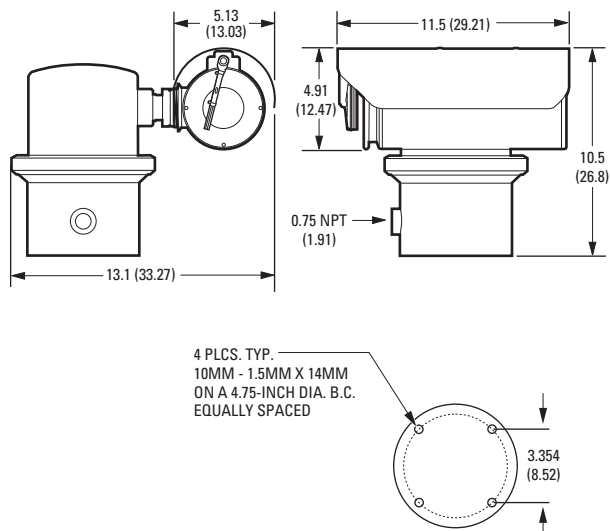

NOTE: Values in parentheses are centimeters; all others are inches.

CAMERA/OPTICS

Camera	Day/Night (23X) Color	LowLight™ (22X) Color
Signal Format	NTSC, PAL	NTSC, PAL
Scanning System	2:1 Interlace	2:1 Interlace
Image Sensor	1/4-inch progressive scan CCD	1/4-inch EXview HAD™ CCD
Effective Pixels NTSC PAL	768 (H) x 494 (V) 752 (H) x 582 (V)	768 (H) x 494 (V) 752 (H) x 582 (V)
Horizontal Resolution NTSC PAL	540 TV lines 540 TV lines	>470 TV lines >460 TV lines
Lens	f/1.6 (focal length, 3.6~82.8 mm optical)	f/1.6 (focal length, 4~88 mm optical)
Zoom	23X optical, 10X digital	22X optical, 12X digital
Zoom Speed	2.9/4.2/5.8 seconds	2.4/3.9/6.3 seconds
Horizontal Angle of View	54° at 3.6 mm wide zoom 2.5° at 82.8 mm telephoto zoom	47° at 4.0 mm wide zoom 2.2° at 88 mm telephoto zoom
Focus	Automatic with manual override	Automatic with manual override
Maximum Sensitivity at 35 IRE NTSC PAL	0.025 lux at 1/2 sec shutter (color) 0.1 lux at 1/60 sec shutter (B-W) 0.004 lux at 1/2 sec shutter (B-W) 0.025 lux at 1/1.5 sec shutter (color) 0.1 lux at 1/50 sec shutter (B-W) 0.004 lux at 1/1.5 sec shutter (B-W)	0.02 lux at 1/2 sec shutter 0.02 lux at 1/1.5 sec shutter
Sync System	Internal/AC line lock, phase adjustable using remote control, V-Sync*	Internal/AC line lock, phase adjustable using remote control, V-Sync*
White Balance	Automatic with manual override*	Automatic with manual override*
Shutter Speed NTSC PAL	Automatic (electronic iris)/Manual 1/2~1/30,000* 1/1.5~1/30,000*	Automatic (electronic iris)/Manual 1/2~1/30,000* 1/1.5~1/30,000*
Iris Control	Automatic Iris Control with manual override*	Automatic Iris Control with manual override*
Gain Control	Automatic/OFF*	Automatic/OFF*
Video Output	1 Vp-p, 75 ohms	1 Vp-p, 75 ohms
Video Signal to Noise	>50 dB	>50 dB

*Manual control of camera setup functions can be done with CM6700, CM6800, CM8500, CM9500, CM9740, CM9760, CM9770, CM9780, KBD200A, KBD300A, and MPT9500 controllers, but not with CM7500, MPT9000, or KBD9000 controllers.

PRODUCT WARRANTY AND RETURN INFORMATION

WARRANTY

Pelco will repair or replace, without charge, any merchandise proved defective in material or workmanship **for a period of one year** after the date of shipment.

Exceptions to this warranty are as noted below:

- Five years:
 - Fiber optic products
 - TW3000 Series unshielded twisted pair (UTP) transmission products
 - CC3701H-2, CC3701H-2X, CC3751H-2, CC3651H-2X, MC3651H-2, and MC3651H-2X camera models
- Three years:
 - Pelco-branded fixed camera models (CCC1390H Series, C10DN Series, C10CH Series, IP3701H Series, and IX Series)
 - EH1500 Series enclosures
 - Spectra® IV products (including Spectra IV IP)
 - Camclosure® Series (IS, ICS, IP) integrated camera systems
 - DX Series digital video recorders, DVR5100 Series digital video recorders, Digital Sentry® Series hardware products, DVX Series digital video recorders, and NVR300 Series network video recorders
 - Endura® Series distributed network-based video products
 - Genex® Series products (multiplexers, server, and keyboard)
 - PMCL200/300/400 Series LCD monitors
- Two years:
 - Standard varifocal, fixed focal, and motorized zoom lenses
 - DF5/DF8 Series fixed dome products
 - Legacy® Series integrated positioning systems
 - Spectra III™, Spectra Mini, Spectra Mini IP, Esprit®, ExSite®, and PS20 scanners, including when used in continuous motion applications.
 - Esprit Ti and TI2500 Series thermal imaging products
 - Esprit and WW5700 Series window wiper (excluding wiper blades).
 - CM6700/CM6800/CM9700 Series matrix
 - Digital Light Processing (DLP®) displays (except lamp and color wheel). The lamp and color wheel will be covered for a period of 90 days. The air filter is not covered under warranty.
 - Intelli-M® eIDC controllers
- One year:
 - Video cassette recorders (VCRs), except video heads. Video heads will be covered for a period of six months.
- Six months:
 - All pan and tilts, scanners, or preset lenses used in continuous motion applications (preset scan, tour, and auto scan modes).

Pelco will warrant all replacement parts and repairs for 90 days from the date of Pelco shipment. All goods requiring warranty repair shall be sent freight prepaid to a Pelco designated location. Repairs made necessary by reason of misuse, alteration, normal wear, or accident are not covered under this warranty.

Pelco assumes no risk and shall be subject to no liability for damages or loss resulting from the specific use or application made of the Products. Pelco's liability for any claim, whether based on breach of contract, negligence, infringement of any rights of any party or product liability, relating to the Products shall not exceed the price paid by the Dealer to Pelco for such Products. In no event will Pelco be liable for any special, incidental, or consequential damages (including loss of use, loss of profit, and claims of third parties) however caused, whether by the negligence of Pelco or otherwise.

The above warranty provides the Dealer with specific legal rights. The Dealer may also have additional rights, which are subject to variation from state to state.

If a warranty repair is required, the Dealer must contact Pelco at (800) 289-9100 or (559) 292-1981 to obtain a Repair Authorization number (RA), and provide the following information:

1. Model and serial number
2. Date of shipment, P.O. number, sales order number, or Pelco invoice number
3. Details of the defect or problem

If there is a dispute regarding the warranty of a product that does not fall under the warranty conditions stated above, please include a written explanation with the product when returned.

Method of return shipment shall be the same or equal to the method by which the item was received by Pelco.

RETURNS

To expedite parts returned for repair or credit, please call Pelco at (800) 289-9100 or (559) 292-1981 to obtain an authorization number (CA number if returned for credit, and RA number if returned for repair) and designated return location.

All merchandise returned for credit may be subject to a 20 percent restocking and refurbishing charge.

Goods returned for repair or credit should be clearly identified with the assigned CA or RA number and freight should be prepaid.

12-23-08

 The materials used in the manufacture of this document and its components are compliant to the requirements of Directive 2002/95/EC.



This equipment contains electrical or electronic components that must be recycled properly to comply with Directive 2002/96/EC of the European Union regarding the disposal of waste electrical and electronic equipment (WEEE). Contact your local dealer for procedures for recycling this equipment.

REVISION HISTORY

Manual #	Date	Comments
C1306M	8/05	Original version.
C1306M-A	7/06	Updated for the new factory-installed power module seal (ECO 06-1400). Revised power module installation instructions. Removed Figure 9.
C1306M-B	10/06	Removed color reference to power module seal (ECO 06-14300). Added power module warning. Added Figure 9.
C1306M-C	11/08	Changed camera specs per CN22046.
C1306M-D	7/09	Updated Important Safety Instructions section and added product certifications; UL certification requirement. Reference CN22827.

PELCO

by **Schneider** Electric

www.pelco.com

Pelco, Inc. Worldwide Headquarters 3500 Pelco Way Clovis, California 93612 USA
USA & Canada Tel (800) 289-9100 Fax (800) 289-9150
International Tel +1 (559) 292-1981 Fax +1 (559) 348-1120